

Collete, Lily, Melody, & Lele Painting Instructions

Materials Needed:

Bell's Gold Marque slip: Fashion White with food coloring mixed in for the eyes. French Glow for Collete and Lily, Cinnamon for Melody, and Champagne for Lele. Distilled water for thinning slip. About 2 feet of clear flexible vinyl tubing with 1/8" interior diameter with a cocktail straw inserted into one end for blowing out the smaller molds. Size 8, 10, 16 & 22mm ball tools. An Exacto blade and small soft acrylic brushes for cleaning greenware. Porcelain sand.

Wigs by Global:

Lily: "Lily" (mohair) in Auburn, Dark Blond or Honey Blond size 4-5.

Collete: "Colette" (mohair) in Light Brown or Dark Blond size 4-5.

Melody: "Love" (mohair) in Black size 4-5. (You can make your own wig from a 3 1/2" square of sheep skin. The curl on the sheepskin should be no more than 1/4" in diameter. Use Dark Brown hair dye or Rit dye, to dye the sheepskin.

Lele: "Suzy" (mohair) in Black size 4-5. (Or make your own - see the "Mohair Wig" sheet).

China paints:

First Kiss, Old Master Red, Dark Brown, German Brown (medium brown) and Black by Virginia LaVorgna. (800-222-3831 orders only) and Eye Blue by Jean Nordquist. (800-468-3655 orders only). I recommend water base medium for this project; it works better for small things.

Brushes:

P08 eyelash #1 (a 3/8" long very fine lash brush), P10 #1, and P15#3 tiny stipplers-by Otto Lindemann; (Pacific International Corp. (702-452-2133).

Medium stippler, (tiny) square shader, lip brush and pointer brush by Jean Nordquist

Pouring:

Mix and strain porcelain slip. Warm one end of your vinyl tubing in hot water and insert your cocktail straw in the end about 1/4" deep. Pour 3/4 cup of slip into a 1 cup measuring cup; add 2 teaspoons of distilled water and mix. This is for pouring the hands and feet. In a small container like an eggcup mix 1 teaspoon of white slip a drop of blue food coloring and 2 or 3 drops of distilled water. Now you are ready to start pouring.

Open the head mold. With a small lip brush paint the eyeball area with blue dyed slip. The blue dye is there to help you see where you have painted. Wait 30 seconds between coats, I do 3 coats. Strap the head mold closed. Next pour the flesh color. Pour the torso, head, upper legs and upper arms in that order. With the thinned slip in the measuring cup pour the lower legs, and lower arms in that order. Wait about 1 minute then pour out arm molds and then leg molds. You will probably need to insert the cocktail straw into the hand mold and foot mold and blow air into it through the vinyl tubing to clear out the excess porcelain.

Note: It is important not to let the porcelain get too thick in the balls of the lower arms and legs or it will be difficult to get the elastic in later.

Pour out the head and torso molds. Let molds stand until porcelain pulls away from the sides of the molds, about 30 minutes, then open the molds.

Remove sprues from all pieces. Using an exacto blade cut out notches in the back of the knee and elbows joints and smooth the edges, keeping in mind that the elastic will be sliding in the notch when you bend her leg or arm. Cut out shoulder and hip holes following the guidelines and cut a small hole in the top of the neck. Cut small shoulder holes and small holes in the sockets of the upper arms and upper legs. Allow pieces to dry.

Cleaning:

Clean seams with an exacto blade and smooth with a very soft acrylic paintbrush. Use brushes and finger tips to clean porcelain.

Size holes as follows: Top of head 14mm, Neck 8mm, Shoulders 16mm, Upper waist 16mm, Lower waist 20mm, Hip sockets 22mm.

Smooth out upper arm elbow socket with 10mm ball tool and upper leg knee sockets with 14mm ball tool. Carefully test all sockets and joints for fit. Lay the greenware on a bed of porcelain sand in your kiln and fire at cone 6.

Painting:

Scrub pieces well with 220 grit scrubber or sanding flap wheel and wipe off all dust. With your palate knife and medium of your choice mix the colors you will be using to the consistency of toothpaste. I use water base paint. All 3 dolls are painted the same way with a few exceptions, which are mentioned below. When I am trying to get extremely fine dark lines I drag my lash brush through a tiny puddle of water on my palate then through my paint until the brush is loaded to my satisfaction, all the while making test strokes on my palate.

Firing #1:

Collete: Starting with your lash brush and dark brown paint, paint a fine line in the crease of the upper eye lid and another one just under the edge of the upper lid. Drag the very tip of the lash brush through the second line and upward to create an eyelash. Repeat until all the upper lashes are done. Load the tip of the brush and paint lower lashes from the outside corner of the lower lid to the middle. I don't go any farther than that because it closes up the eyes and you lose the wide-eyed innocent look. Now paint the eyebrows.

Lily: Repeat the above except use Seeley's eyebrow #6, Dark Champagne for eyebrows.

Blond Melody: same as Collete but use Seeley's Russet mixed with Light Brown for brow color and freckles.

Melody and LeLe: Repeat the above step using Black paint.

With your spotter brush loaded with First Kiss paint nose dots. Wipe any excess from brush and paint light coat of First Kiss on lips. Dampen cheeks with medium and blot. Blush cheeks, tip of chin, toe and finger nails with First Kiss. Fire at cone .018.

Firing #2:

Collete: Eye shadow is a half-and-half mix of Eye Blue and Old Master Red. Load lash brush as you did for eyelashes and paint a line of color in the eyelid crease. Use your p10 and p15 stipplers to blend the line upward creating the eye shadow. Load your lip brush with the shadow color and paint the irises (the colored part of the eyes). With your pointer paint a tiny dot of First Kiss in the tear ducts. Using your pointer paint accents on the lips and shade with p10 stippler. Add a little more blush to the cheeks in Old Master Red.

Lily: same as Collete except use a blue gray color for irises

Melody and Lele: substitute Brown for the Eye Blue and paint eyes as you did Collete.

Fire at cone 018

Firing #3:

Wet your lip brush with water then blot the excess water. Load the brush with black paint and paint the pupils of the eyes. You will notice when you use water in this way you can get a nice dark area with out using much paint. Let the pupils dry for 15 minutes. Dampen your pointer with water and load it with white paint. Paint a tiny white dot on the left upper edge of the pupil for the light reflection. Fire at cone .018

Making the Melody Sheepskin Wig

1) Cut out paper pattern and trace it on to a 3" x 3" piece of sheepskin. Use small sharp scissors. Slide the top blade under the fur and above the skin, so you will cut as little of the fur off as possible, and cut the wig out.

2) At this point you could just glue the wig on with tacky glue; but I prefer to baste the edges together then fit it to the head and make little adjustments. Cut a curved notch in each side for the ears to peek out. When you are satisfied with the fit, glue wig down to head and let dry for an hour or so.

3) Using a "T" pin or a tapestry needle like a hair pick, fluff out the curls. Trim off any straggly curls, spray wig with a fine mist of water to make it curl, and let dry. Now is a good time to put a small silk ribbon in her hair if you want to. Cover her face and spray on a light mist of hair spray. Now stand back and admire your work.

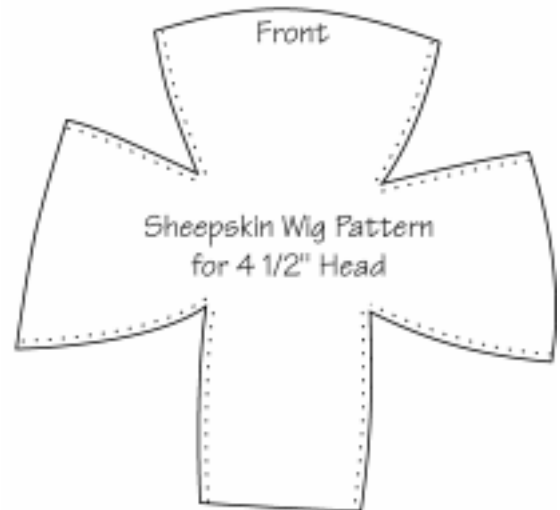

Sheepskin with tiny curls available from:

South Forty Farms
34184 Quail Creek Lane
Wildomar, CA 92595
909-471-2992
<http://www.southfortyfarms.com>

Tip:

Make photocopy of this page and use that to cut out the pattern.

Making Lele's Wooden Sandals

Soles

The sole and the two riser blocks are made from 1/8" thick wood. Cut out two soles and four riser blocks. The riser blocks are 1/8" by 1/8" and long enough to match the sole.

Glue the riser blocks to the soles as shown in the diagram; making sure that you have a right and a left.

Clean off any visible glue after sanding, the shoes can be colored with wood stain, felt markers, or wax shoe polish.

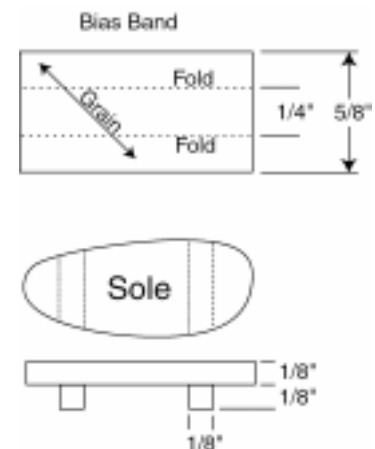

Bias Band

The band can be made from the fabric scraps left over from making the Kimono.

Cut the band 5/8" wide, on the bias, and long enough so that it is easy to work with.

Fold and press as in the diagram.

Glue the soles to the doll's feet using tacky glue.

After the glue has dried, wrap the bias band around the foot and the sole so that it looks right. Cut to length and glue the ends to the undersides of the soles.